

**MANUAL, & SELF-PROPELLED**

**GAS-POWERED**

**ALUMINUM SCREED**

**OPERATION, MAINTENANCE  
and PARTS MANUAL**

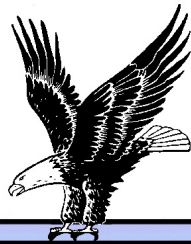
**Publication M48102  
(Revised 03/15)**

**MODEL NUMBER:** \_\_\_\_\_

**SERIAL NUMBER:** \_\_\_\_\_

**SOLD & SERVICED BY:** \_\_\_\_\_

\_\_\_\_\_



**MASTER**

**MASTER EQUIPMENT**

850 State Hwy 55 • Brooten MN 56316  
[www.Master.Equipment](http://www.Master.Equipment)

# Table of Contents

---

## ASSEMBLY AND OPERATION

Application. ....	1-1
Assembly.....	1-1
Alignment. ....	1-7
Safety.....	1-8
Operation.....	1-9
Operation Tips. ....	1-10
Lubrication. ....	1-10

## PARTS

Screed Section Assembly .....	2-1
Power Unit Assembly . ....	2-2
Screed Frame Assembly . ....	2-4
End Section Assembly . ....	2-6

## BOLT AND CAP SCREW TORQUE SPECIFICATIONS

Bolt and Cap Screw Torque Specifications.....	3-1
Warranty. ....	3-2

# Assembly & Operation

---

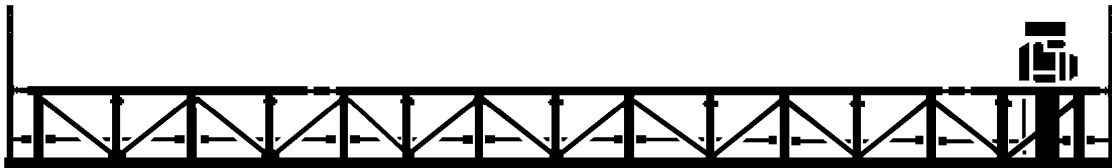
## APPLICATION

The manual & self-propelled screeds can be assembled in 2.5' increments using a combination of 7.5', 5' and 2.5' sections. The screed length should be at least 1 foot longer than the inside width of the forms, but not in excess of 2 feet on either side. Crown can be adjustable to a maximum of 2 inches per 10 foot span.

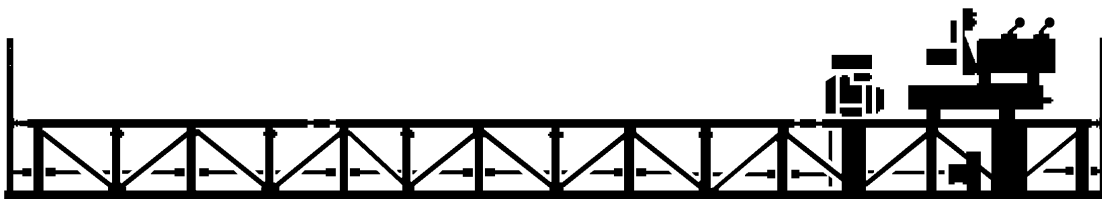
**Maximum screed length is 60 linear feet.**

## ASSEMBLY

- Begin by selecting a flat surface on which to assemble the screed (see Figures 1-1 and 1-2).
- Start with the power section and position it on the right side of the pour, with the curl edge to the front.



*Figure 1-1  
Typical Assembly - Manual Screed*



*Figure 1-2  
Typical Assembly - Self-Propelled Screed*

## Page 1-2 - Assembly and Operation

Assembly - cont'd.

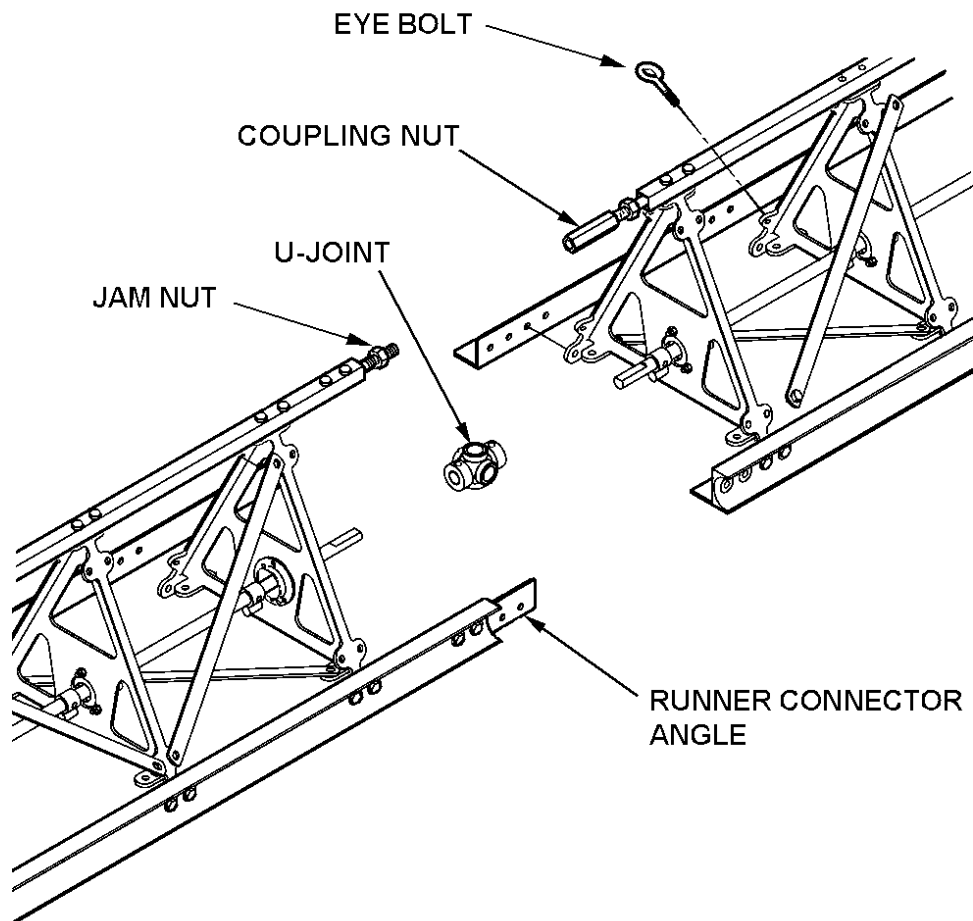
- Remove the loose bolts from the runner connector angles and set them aside for reassembly.
- Remove the top coupling nut. Thread the coupling nut onto both threaded rods at the same time

*Note: The threaded rods are opposite threads (one right-hand, one left-hand.) Tightening the coupling nut will draw the screed sections together.*

- As the sections draw together, make sure the eccentric shaft U-joint is in place and the vibration shafts are aligned. The machined flat on the vibration shaft must line-up with the set screws in the U-joint.

*Note: Make sure the eccentric weights on the vibration shaft are all offset to the same side of the shaft across the entire span. Improperly aligned weights can impart a "balancing" effect, which reduces vibration and causes poor performance.*

- Continue turning the coupling nut until both the front and rear runners meet. Secure the sections together using the runner connector angles on both runners, with previously removed 3/8" x 1" bolts. Tighten the jam nuts next to the coupling nuts.
- Tighten both set screws in the vibration shaft U-joint using a 1/4" hex key. Install the bottom and side braces with the hardware provided. Be sure to tighten the bolts at this time.



**Figure 1-3**  
**Screed Section Assembly**

Assembly - cont'd.

- Repeat the above steps for the remaining screed sections until the proper length is achieved. (Refer to APPLICATION for details on length.)
- Install the end sections on each end with the desired winch and cable setup. (see Figure 1-4.)

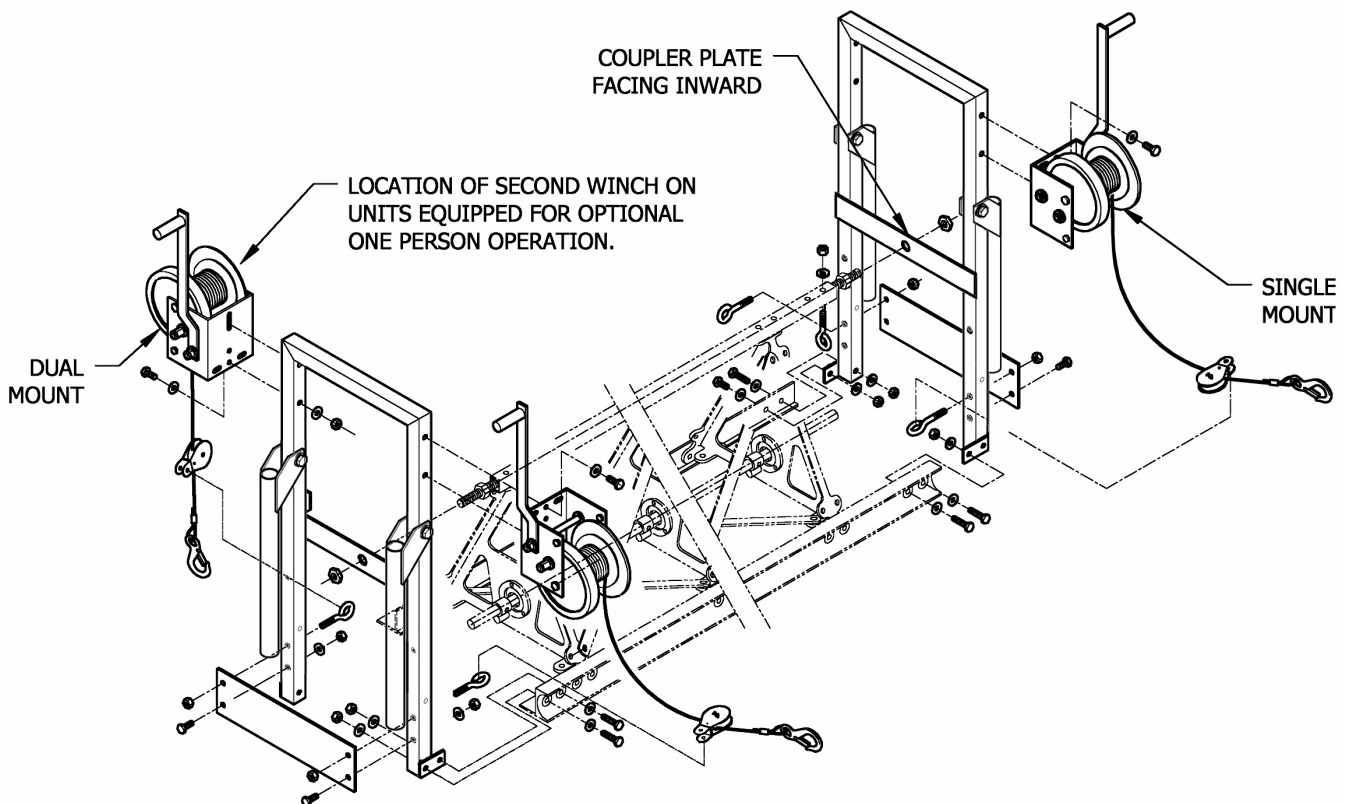
## Manual-Screed End Section and Cable Installation

### MANUAL-SCREED

*Note: End sections are shipped assembled and need only be installed on each end of the screed. Once the end sections are installed, it is recommended to leave them assembled and just adjust the number of interior sections to adapt the screed to different lengths. This will save setup time on future jobs.*

#### Standard Single-Mount

- To install the standard single-mount end sections, position the winches toward the front (curl edge) of the screed, with the coupler mounting plate facing inward (see Figure 1-4.) Secure the end sections to both runners and the top tube as shown in Figure 1-4. Be sure to install one eye-bolt under each winch as shown
- Install the cable pulleys from each winch to the eye bolts as shown in Figure 1-4. It may be necessary to disengage the winch lock and unwind some cable.



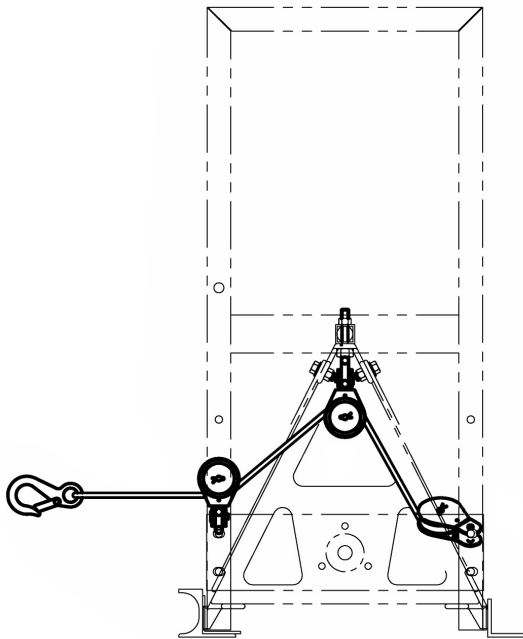
**Figure 1-4**  
**Manual Screed End Section Installation**

## Page 1-4 - Assembly and Operation

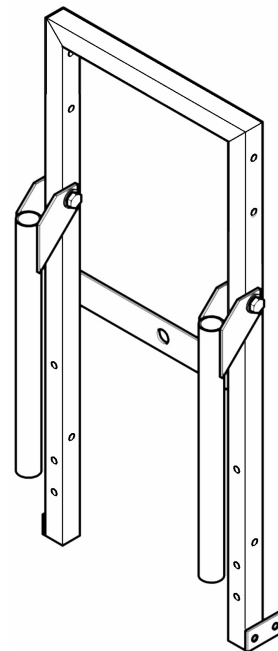
*End Section and Cable Installation - cont'd.*

### Optional Dual-Mount Winches

- The optional dual-mount winches can be installed on either end section of the screed. To install the end sections, position both end sections with the coupler mounting plate facing inward (see Figure 1-4.) Secure the end sections to both runners and the top tube as shown in Figure 1-4. Install eye bolts under each winch (see Figure 1-4); one eye-bolt in the front of the end section and one eye-bolt in the rear.
- Install the cable pulleys from each winch to the eye bolts as shown in Figure 1-4. It will be necessary to disengage the winch lock and unwind some cable.
- With the optional dual-mount winches, the rear winch cable must be routed along the back of the screed to reach the left side, where it must cross-over and come back out the front side. Install the three eye-bolts for the cross-over at the last A-frame on the left end of the screed opposite the winches (see Figure 1-5); one eye-bolt on the rear of the end section, one eye-bolt on the top tube, and one eye-bolt in the front of the end section. Refer to Figure 1-5, and install the cross-over pulleys..
- Install eye-bolts along the rear A-frames (see figure 1-3) to help secure and guide the cable; one eye-bolt for every 10 feet of screed length.
- Install the cable pulley from the front winch to the eye bolt in the front runner as shown in Figure 1-4. It will be necessary to disengage the winch lock and unwind some cable.
- To route the rear cable, install the cable pulley from the rear winch to the eye bolt directly beneath it in the rear of the end section as shown in Figure 1-4. Disengage the winch lock and unwind enough cable to reach the opposite end of the screed. Route the cable through the eye-bolts on the rear to the far end of the screed.
- Install the cable into the cross-over pulleys at the left side (see Figure 1-5). The cable pulleys must be taken apart and reassembled when installing the cable.



**Figure 1-5**  
**Cross-Over Installation**  
**LH Side**

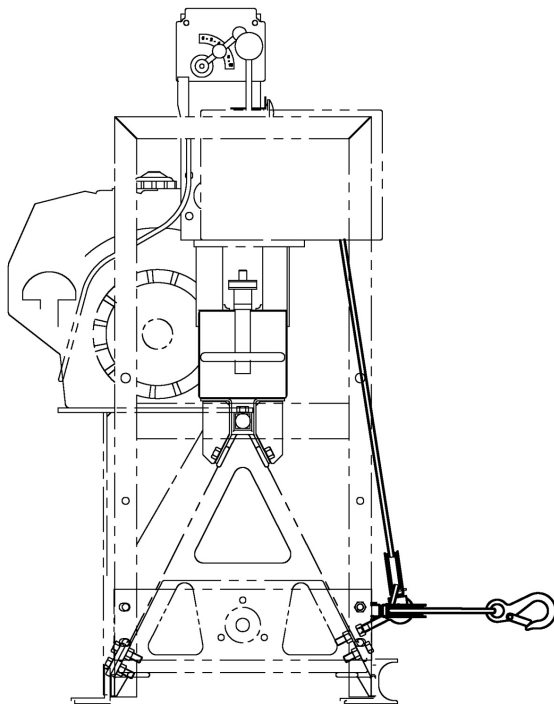


**Figure 1-5a**  
**End Section and Method**  
**of Handle Installation**  
**for Manual Operation**

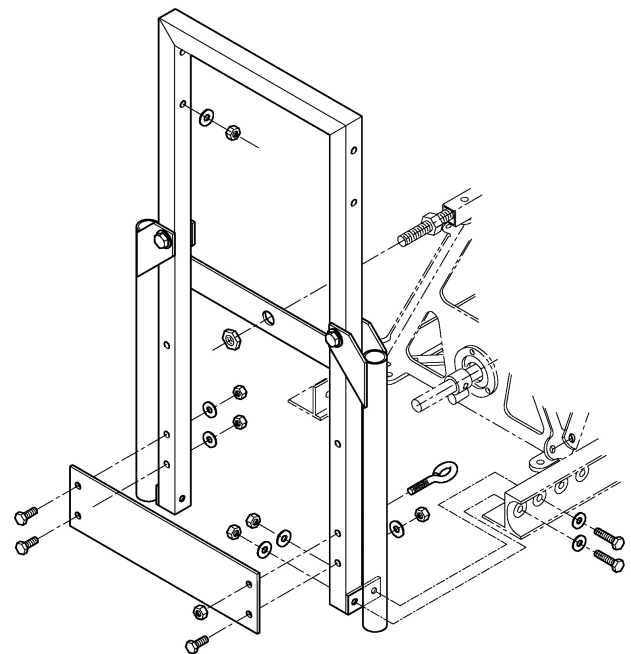
*End Section and Cable Installation - cont'd.*

**Optional Self-Propelled Drive**

- On the self-propelled screed, the winches are part of the hydraulic drive and the end sections are used for protection and handling. The end sections are identical so they may be installed on either end. To install the end sections, position both end sections with the coupler mounting plate facing inward (see Figure 1-7.) Secure the end sections to both runners and the top tube as shown in Figure 1-7.
- With the self-propelled screed, one cable must be routed along the front of the screed to reach the left side, eye-bolt and pulley (see Figure 1-9).
- Install eye-bolts along the front A-frames (see Figure 1-6) to help secure and guide the cable; one eye-bolt minimum for every 10 feet of screed length.
- Disengage the winch control lever (see Figure 1-8) for the back-side cable winch (this permits the cable to be fed freely from the cable drum) and unwind enough cable to reach the opposite end of the screed. Route the cable through the eye-bolts in the rear runner to the far end of the screed.
- Install the cable into the cross-over pulleys at the left end (see Figure 1-6). The cable pulleys must be taken apart and reassembled when installing the cable.

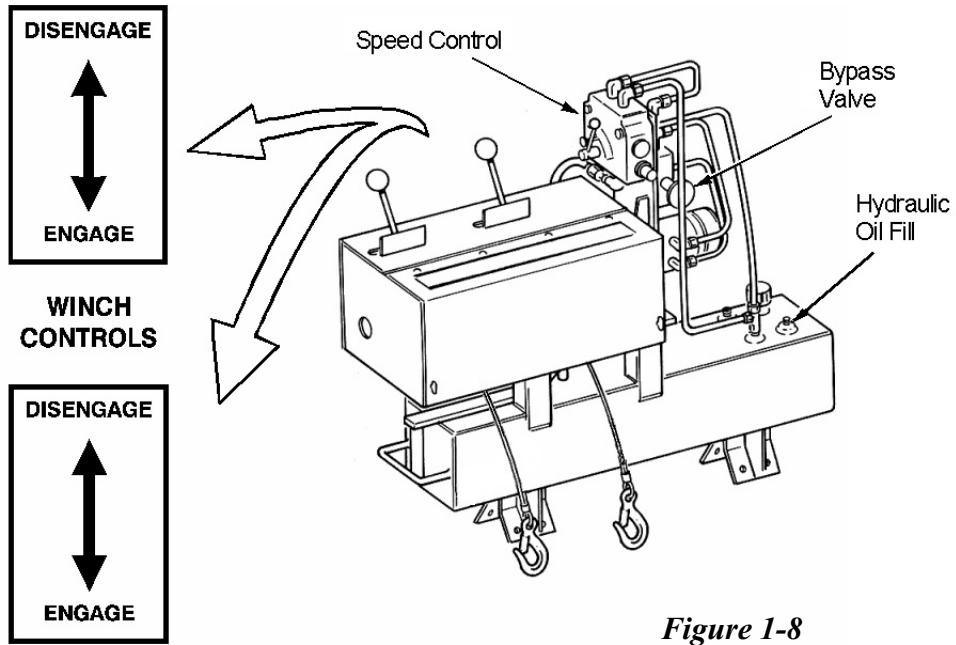


**Figure 1-6**  
**Cable Installation**  
**Drive Side or RH Side**

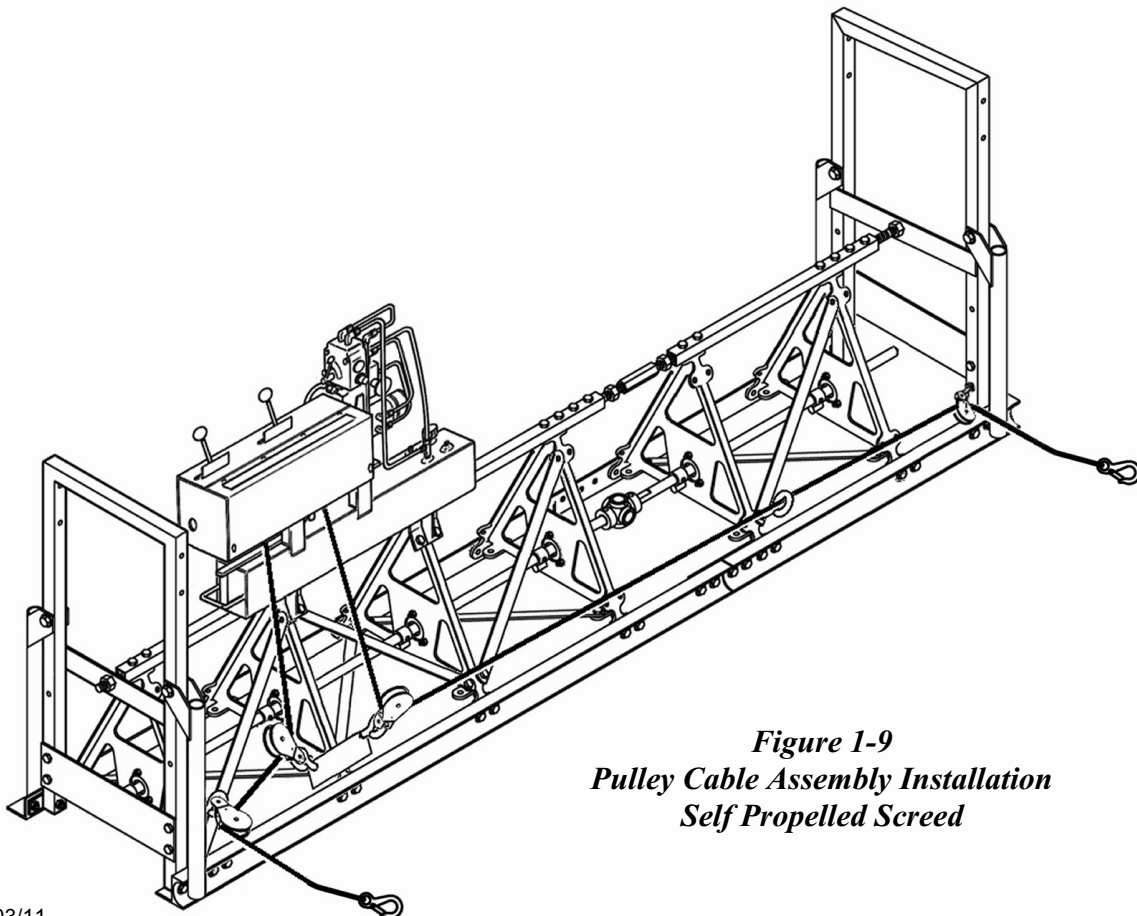


**Figure 1-6a**  
**End Section and Method of Handle**  
**Installation for Self Propelled**

End Section and Cable Installation - cont'd.



*Figure 1-8  
Winch Controls - Self Propelled Screed*



*Figure 1-9  
Pulley Cable Assembly Installation  
Self Propelled Screed*



## ALIGNMENT

Once the screed is assembled, place it on the forms and run a string line next to the front and rear runners (see Figure 1-10). At this point the screed can be adjusted for flat, crown, or valley as required.

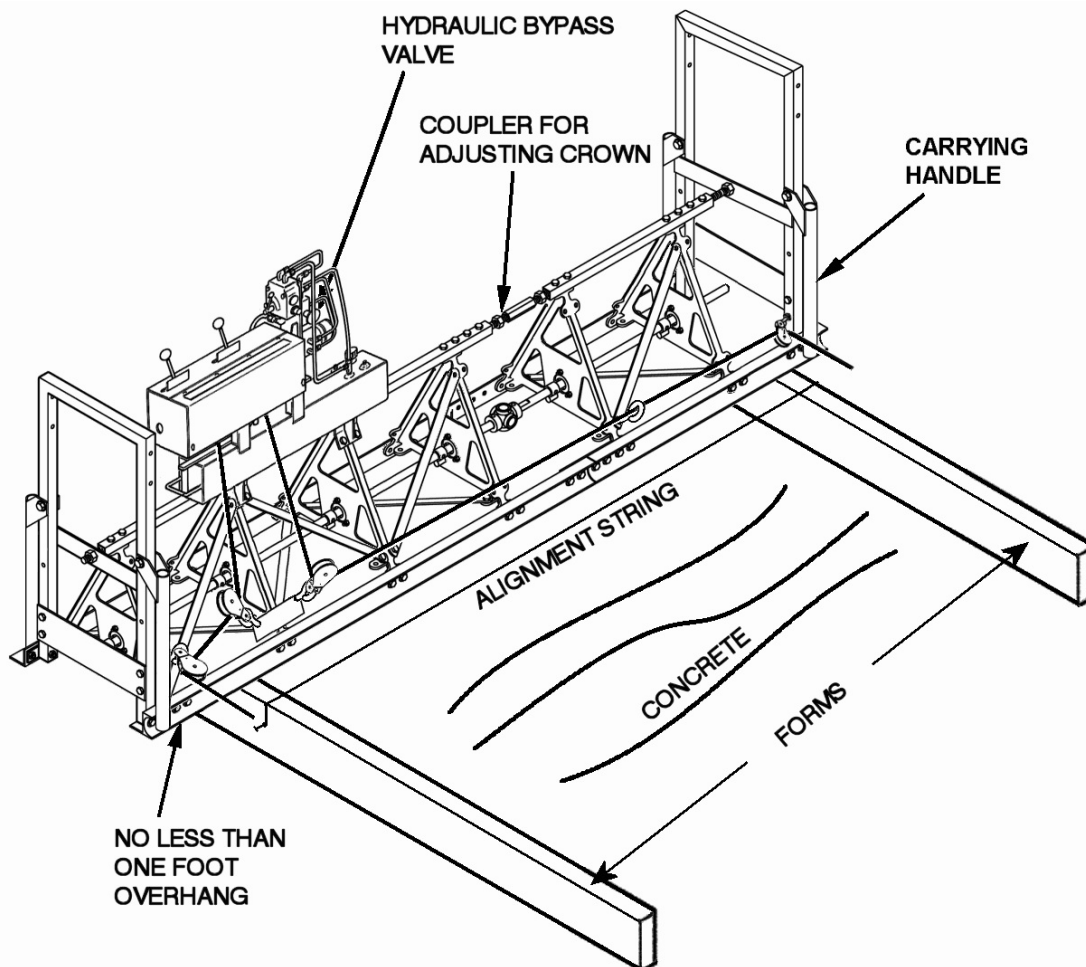
### Flat Alignment

- If adjustment is needed, loosen the jam nuts next to the coupling nut. Adjust the couplers as needed to make sure both front and rear runners are straight and aligned with the string. Tighten the jams nuts next to the coupling nut.

### Crown or Valley Alignment

**IMPORTANT:** When setting up the screed for a crown or valley, the coupling jam nuts, all side straps and bearing flange bolts **MUST** be loosened before adjusting the couplers. Also, one set screw at each U-joint must be loosened. The hardware should be loose enough to allow the side straps and bearings to float. Failing to loosen the side strap and bearing hardware will make any adjustment difficult and can cause poor performance and damage to screed components.

- Adjust the coupling nuts until the required crown or valley is achieved. This is determined by measuring the distance from the runner to the alignment string (either above or below). Be sure to check both front and rear runners. It may be necessary to adjust coupling nuts at several points across the span to achieve the proper setting.



*Figure 1-10  
Screed Alignment*

## Page 1-8 - Assembly and Operation

*Alignment - cont'd.*

- When the proper crown or valley is achieved, retighten the side straps, jam nuts, and U-joint set screws to hold the screed profile. Turn the eccentric shaft by hand through one full rotation to be sure that it turns freely.
- Before operating the screed, the vibration shaft must be aligned.

**⚠ CAUTION** When aligning the vibration shaft on a self-propelled screed, be sure both winches are disengaged and the speed control is in the slowest position.

- With the bearing flange hardware still loose, start the engine and throttle it up to engage the clutch and rotate the vibration shaft. Run the engine at operational speed for approximately 30 seconds to align the shaft and set the bearings. Stop the engine and retighten all bearing hardware.

## SAFETY

- Read and understand the operating instructions in this manual. Only trained personnel should operate the screed.
- Keep bystanders clear of the work area.
- Stay clear of the cables and moving parts when the screed is operating.
- The cables must be anchored securely to a form pin or other anchored structure.
- Watch the cable and screed movement for any snags when the screed is moving.
- Never leave the screed unattended when it is running.
- Never refuel while the engine is running or hot.
- Exhaust fumes can be lethal. Always operate in a well ventilated area.
- Shut off the engine before doing maintenance or making any adjustments.

**⚠ WARNING** This unit is equipped with an internal combustion engine and should not be used on or near any unimproved forest-covered, brush-covered or grass-covered land unless the engine's exhaust system is equipped with a spark arrester meeting applicable local or state laws (if any). If a spark arrester is used, it should be maintained in effective working order by the operator. In the State of California the above is required by law (Section 4442 of the California Public Resources Code). Other states may have similar laws. Federal laws apply on federal lands. A spark arrester for the muffler is available through your nearest engine authorized service dealer or contact the service department.

## OPERATION

- Coat the screed structure, across the entire span, with form release oil. This prevents concrete from sticking and facilitates clean up.
- Check the engine oil and fuel supply before starting the engine. NOTE: When using a self-propelled screed, check the hydraulic reservoir and verify that it is full (use only non-foaming hydraulic oil).
- Unwind the cable on both ends (approx. 100-120 feet) and attach it securely to a form pin or other structure. The cable should run above the surface of the front runner to minimize tangling on the form line.
- Start the engine and allow it to warm up at idle. Next, momentarily set the speed to half throttle to engage the clutch and eccentric shaft to check for proper operation. In cold weather, operate the engine at half throttle for 5-10 minutes to warm up the bearing grease.

### **CAUTION**

**When starting a self-propelled screed, be sure both winches are disengaged and The speed control is in the slowest position.**

- Set the engine speed to about 3/4 throttle for most slumps of concrete.

### Manual Screed

- Two persons, one on each side, are required when using standard single-mount winches. A dual-mount winch unit is available, and requires only one person for operation.
- Grade the concrete to a level just above the front runner cutting edge. Use the winches to advance the screed down the forms at a uniform rate.
- A thorough water cleaning should be done immediately after use. Wipe the bottom of both runners to clean any residual concrete.
- Relubricate the screed bearings to purge water after pressure washing.

### Self-Propelled Screed

- Only one person is required to operate a self-propelled screed. The screed travel is controlled by the winches control levers. The outboard lever controls the operator's end (right side) of the screed and the inboard lever controls the opposite end (left side) of the screed.
- Make sure the system bypass valve is pulled out (closed) to the operating position.
- Grade the concrete to a level just above the front runner cutting edge. Engage both winch control levers to advance the screed down the forms at a uniform rate.
- To correct for side to side misalignment during operation, momentarily disengage the winch control lever controlling the leading end. Re-engage the winch control lever when the alignment is corrected.
- To increase travel speed (0-20 ft/min), rotate the lever on the speed control valve in a clockwise direction. The speed control has a locking thumbscrew to hold the desired position.
- Manual Operation - To operate the self-propelled screed manually:
  1. Activate the hydraulic system bypass valve (pushed in.)
  2. Attach the crank handle onto the winch shaft.
  3. Turn the crank handle for manual winch operation.

## Page 1-10 - Assembly and Operation

*Operation - cont'd.*

- A thorough water cleaning should be done immediately after use. Wipe the bottom of both runners to clean any residual concrete.
- Relubricate the screed bearings to purge water after pressure cleaning.

## OPERATING TIPS

The manual screed and self-propelled screed can operate at various widths and will handle concrete slump 3" or higher. The success of the screeding operation is still very dependent upon uniform and accurate concrete placement. Workers in the puddle should be evenly spaced and previously instructed on grading procedures and have an overall understanding of how the screed works.

During operation, the screed is supported by the concrete and the vibrating action of the spinning weight shaft actually "hops" the screed forward. This helps to reduce the amount of effort required to advance the screed down the forms. The curling edge cuts the concrete to grade, provided only a small amount of concrete is allowed to flow over the edge. The rough grade should be approximately 1/2" high. Occasionally rake off the excess build-up to maintain the 1/2" high grade. This procedure may be adjusted with the slump of the concrete and the efficiency of the pouring crew.

Once the screed is turned on and moving across the concrete, starting and stopping should be kept to a minimum to achieve a more consistent, uniform surface. When the screed is stopped in the middle of a pour, it will leave small runner impressions in the concrete surface. Pouring out a large area in front of the screed and staying ahead of the screeding operation with the pour, can help eliminate unnecessary stopping. Laying down several feet of concrete, prior to putting the screed on the work area, will eliminate having to pour concrete between the screed runners at the start of each pour (making clean-up much easier).

Turn off the engine when waiting. The engine clutch is intended for cranking - not idling. Continuous idling will also cause wash-back on the pour and could cause the concrete to segregate.

Before re-starting the engine, pick the screed up and set it back about one foot. This should eliminate wash-back due to stopping.

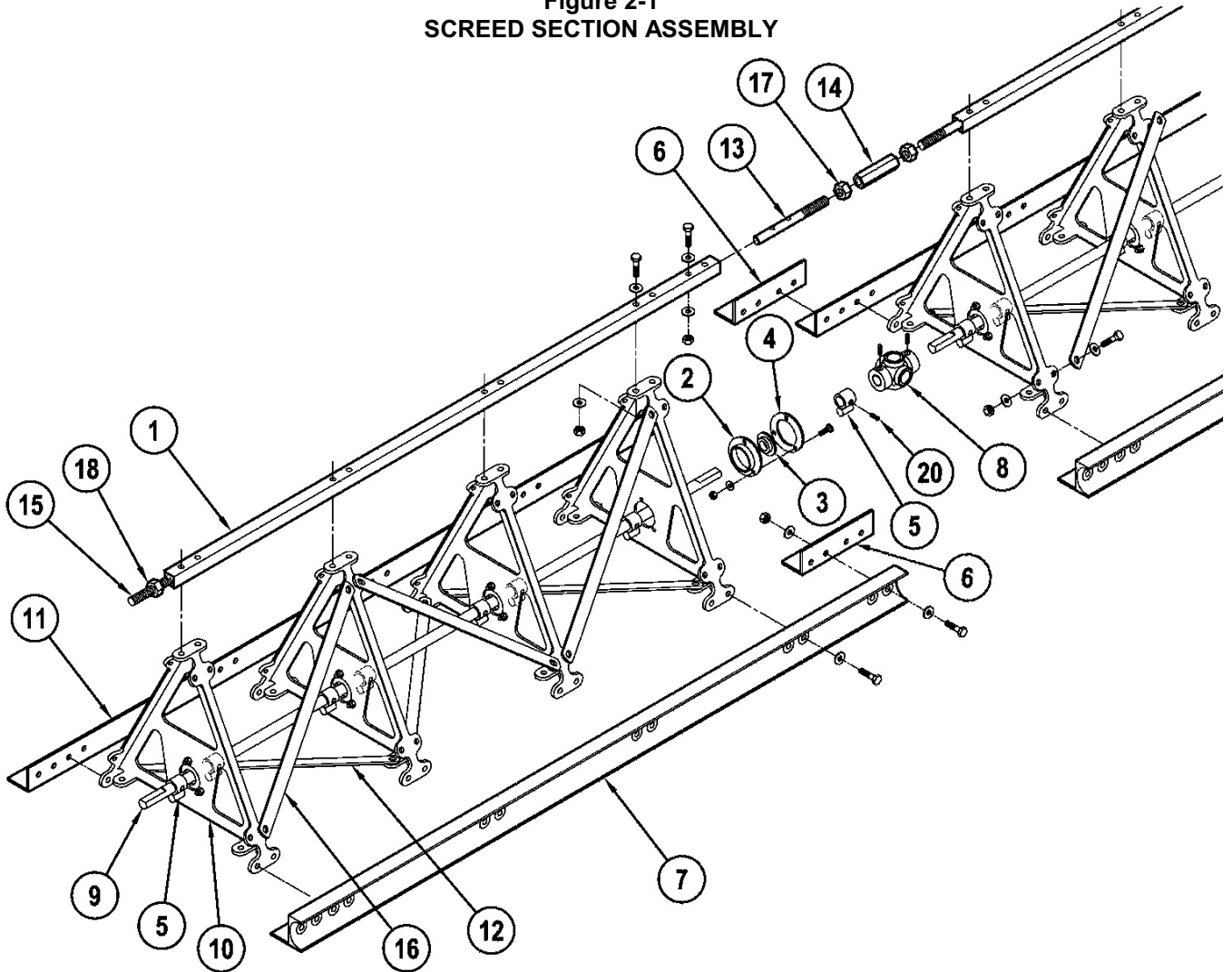
If the space between the curling edge (front runner) and the trailing edge (rear runner) becomes loaded with concrete, set the screed back and insure that the concrete is graded low enough ahead of the curling edge before resuming screeding.

Do not sit on the screed. It is made to span the forms, not to sit on. Excess weight on the top of the screed may cause it to lose its finish grade setting.

## LUBRICATION

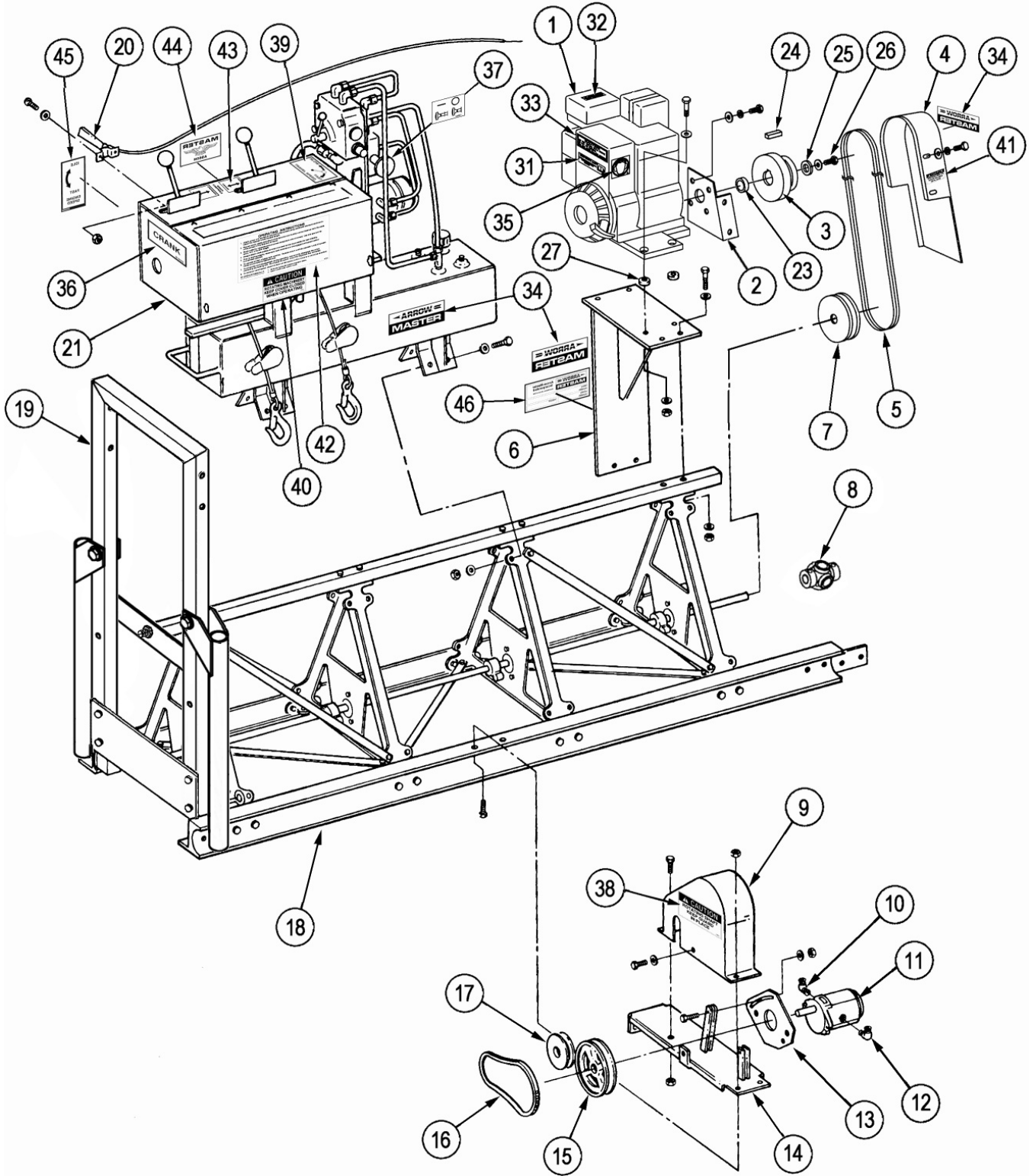
- Check the engine oil daily or before each pour. Refer to the engine manual for instructions.
- Lubricate the bearings with a multi-lube grease after every 50 hours of operation, or after pressure washing the unit. ( see Figure 2-1, Item 4 on page 2-1 for location of grease fittings).
- Open the winch cover (Item 32 on page 2-4) every 50 hours of operation and place a few drops of engine oil on the winch gears and shafts.
- Check the hydraulic oil every 100 hours of operation. The oil level should be 1" below the top surface of the tank fill hole (see Figure 1-8). Use type AW-20 or AW-46 hydraulic fluid.

Figure 2-1  
SCREED SECTION ASSEMBLY



Key No.	Part No.	Description	Key No.	Part No.	Description
1	M45085	Top Tube, (7.5' section only)	10	M45081-01	"A" Frame Support
	M45086	Top Tube, (5' & 10' sections only)	11	M46148	Tail Runner (2.5' section only)
	M45087	Top Tube, (2.5' section only)		M46149	Tail Runner (5' section only)
2	M48068-2	Bearing Flange		M46150	Tail Runner (7.5' section only)
3	M48067	Bearing		.....	Tail Runner (10' section only)
4	M48068-1	Bearing Flange w/Zerk	12	M46275-1	Bottom Strap
5	M45094-01	Eccentric Weight (Includes Item 20)	13	M45112-1	Threaded Rod, RH
6	M45110	Connector Bracket	14	M45113	Top Tube Coupler
7	M46154	Front Runner (2.5' section only)	15	M45112-2	Threaded Rod, LH
	M46155	Front Runner (5' section only)	16	M48275-2	Side Strap
	M46156	Front Runner (7.5' section only)	17	NJC-12C	3/4"-10 Jam Nut, R.H.
.....		Front Runner (10' section only)	18	NJC-12CL	3/4"-10 Jam Nut, LH.
8	M48804	U -Joint	19	M46226	Bearing Assembly (Includes Items 2, 3, & 4)
9	M45091-1	Shaft, Vib. (7.5' section only)	20	SC6-3C	3/8"-16 x 3/8" Soc. Hd. Set Screw
	M45091-2	Shaft, Vib. (5' & 10' sections only)			
	M45091-3	Shaft, Vib. (2.5' section only)			

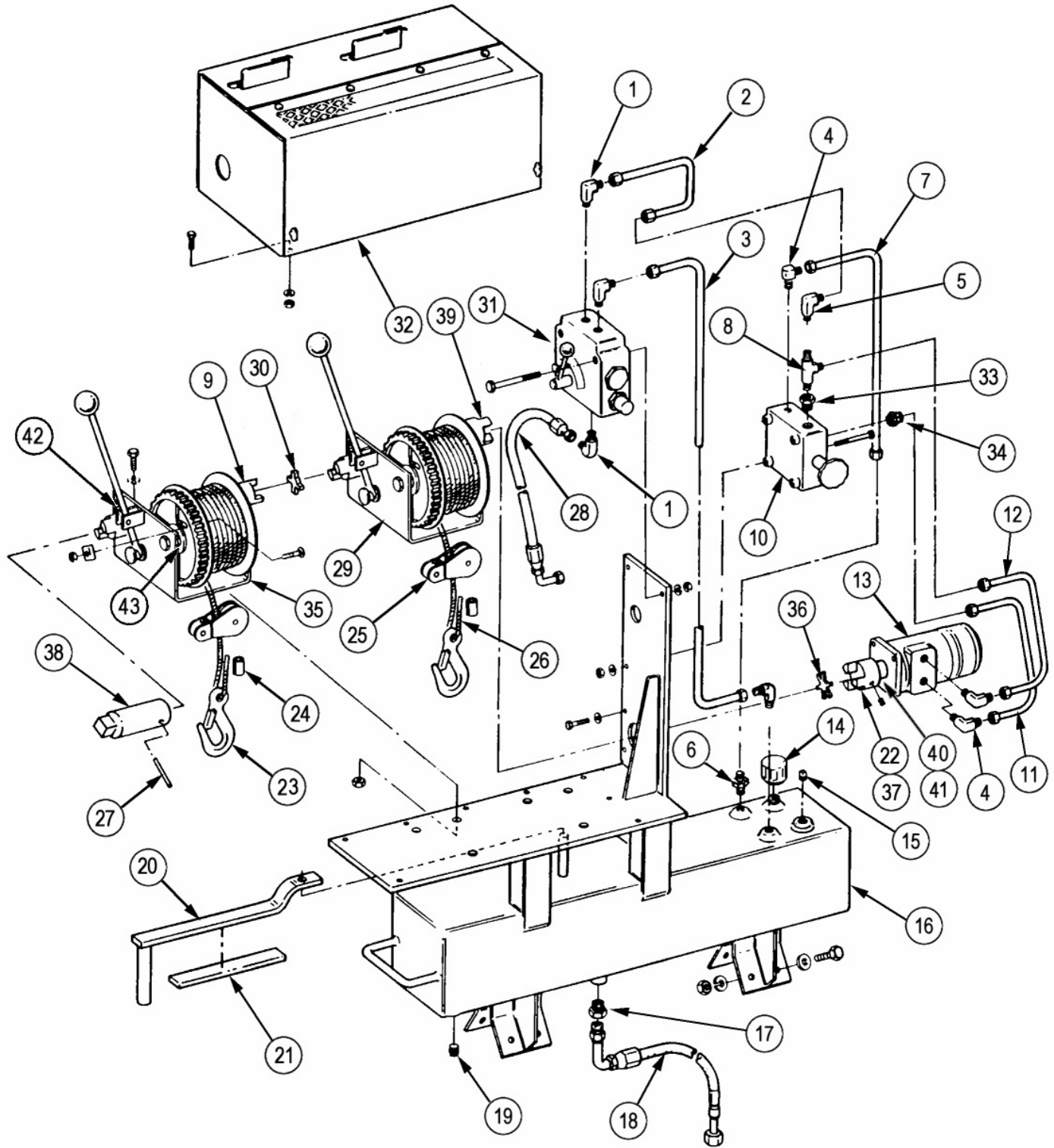
Figure 2-2  
POWER UNIT ASSEMBLY



**Figure 2-2**  
**POWER UNIT ASSEMBLY**

<b>Key No.</b>	<b>Part No.</b>	<b>Description</b>
1	M33008	Engine, Honda 5.5H
	M48968	Engine, Briggs and Stratton 6.5HP
	M32993	Engine, Honda 8HP
	M32676	Engine, Briggs and Stratton 8HP
2	M32995-01	Belt Guard Bracket Assembly
3	M45929	Clutch, 5.5HP & 6.5HP
	M48742	Clutch, 8HP
4	M48949	Belt Guard
5	M45927	V-Belt - 5.5HP & 6.5HP
	M48743	V-Belt - 8HP
6	M45088	Engine Mounting Weldment, 5.5HP & 6.5HP
	M48817	Engine Mounting Weldment, 8HP
7	M45928	Pulley
8	M48804	U-Joint
9	M46631	Guard Weldment (Self-propelled only)
10	M46733-11	Elbow, Str. Thread (Self-propelled Only)
11	M46619	Hydraulic Pump (Self-propelled Only)
12	M46733-8	Elbow, Str. Thread (Self-propelled Only)
13	M46630	Pump Mounting Plate (Self-propelled Only)
14	M46626	Pump Mount Weldment (Self-propelled Only)
15	M46791	Cast Sheave (Self-propelled Only)
16	M48134	V-belt (Self-propelled Only)
17	M46711	Steel Sheave (Self-propelled Only)
18	M45096-02	Aluminum Screed Assembly, 5' (See Figure 2-1)
19	M45099-01	End Section
20	M46341-08	Throttle Assembly
21	M48975	Hydraulic System Assembly (See Figure 2-3) -2006
	M49018	Hydraulic System Assembly (See Figure 2-3) 2007-
23	M19535	Clutch Spacer - Briggs 6.5hp (3), Honda 5.5hp (4)
24	K3-12	Square Key, 3/16" X 1-1/2"
	K4-10	Square Key, 1/4" X 1-1/4", 8hp
25	805433-3	Flat Washer
26	H5F5-7C	Clutch Bolt. 5/16"-24 x 7/8"
	H5F7-8C	Hex Hd Screw 7/16-20 x 1", 8 HP
27	T631116	Vibration Spacer
31	M29938	Read Instructions Decal
32	M32063	Hot Muffler Decal
33	M32117	Do not Refuel Decal
34	M45010	Arrow-Master Logo Decal
35	M46461	Ear Protection Required Decal
36	M48022	Crank Decal
37	M48023	Hydraulic System Bypass Decal
38	M32167	Keep Hands Clear Decal
39	M48025	Travel Speed Decal
40	M32167	Keep Hands Clear Decal
41	M48027	Caution Moving Belts Decal
42	M48028	Operating Instructions Decal
43	M48029	Winch Controls Decal
44	M48030	Master Eagle Decal
45	M48032	Engine Speed Decal
46	M 5621	Serial Number Plate

Figure 2-3  
SCREED FRAME ASSEMBLY  
Self-Propelled

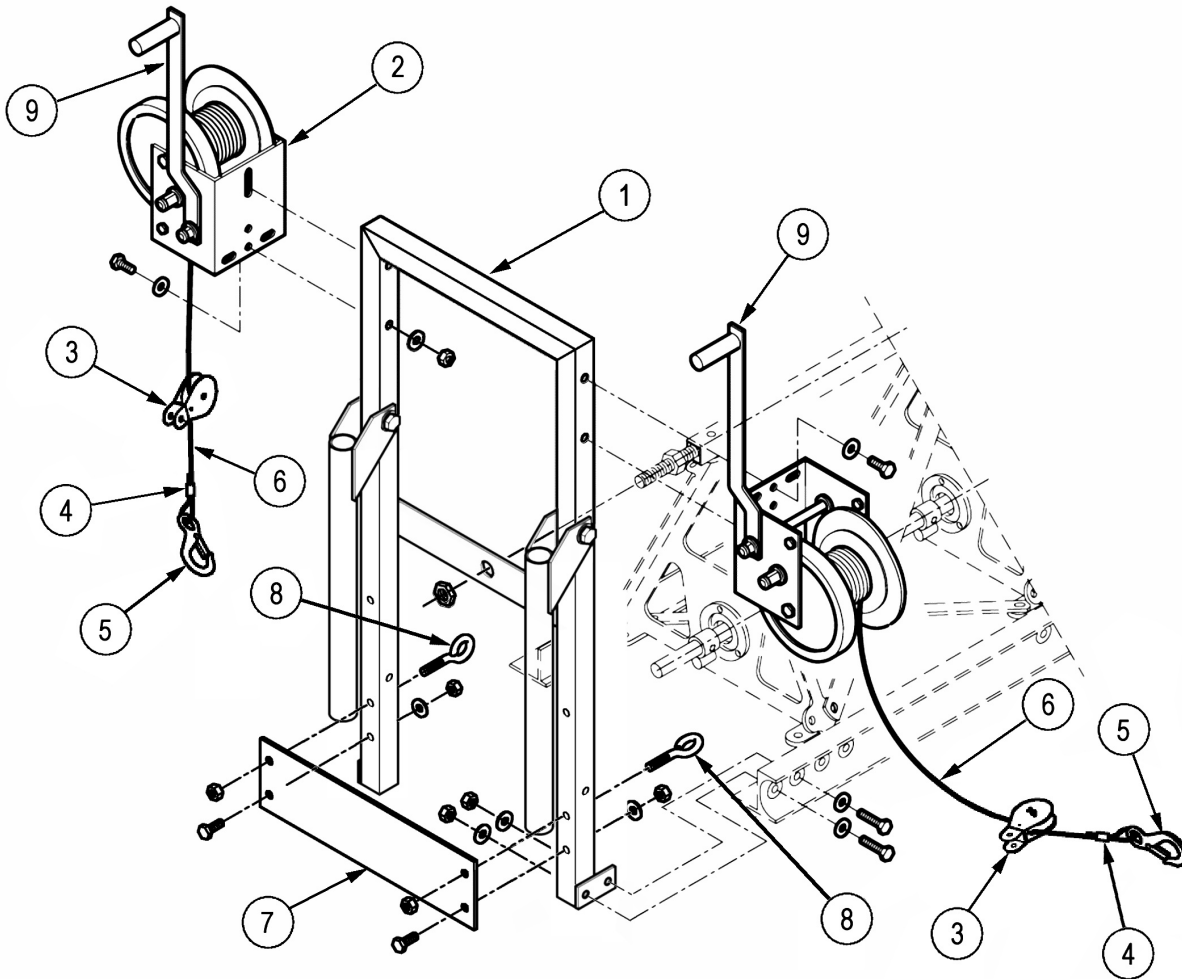




**Figure 2-3**  
**SCREED FRAME ASSEMBLY**  
**Self-Propelled**

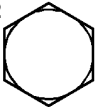
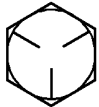


<b>Key No.</b>	<b>Part No.</b>	<b>Description</b>
1	M46772-10	Elbow Adapter, 90° 3/8P-3/8T
2	M46778	Hose, Flow Valve to Bypass Valve
3	M46777	Hose, Flow Valve -Tank
4	M46772-15	Elbow Adapter, 90° 1/2P-3/8T
5	M46790-3	Swivel Nut Elbow Adapter
6	M46771-13	Nipple Adapter, 3/8P-3/8T
7	M46774	Hose, Bypass Valve -Tank
8	M46773-4	Male Run Tee Adapter, 1 /4P-3/8T -3/8T
9	M46950	Coupling
10	M46726	Directional Control Valve
11	M46775	Hose, Motor -Bypass Valve
12	M46776	Hose, Bypass Valve -Motor
13	M46618	Hydraulic Motor
14	M46760	Breather Cap
15	M 8257	1/2" Pipe Plug
16	M46595	Frame Weldment
17	M46771-18	Nipple Adapter. 1/2P-3/4T
18	M46652	Hydraulic Hose Assembly, 1/2" Tank to Pump
19	M48583	3/8" Pipe Plug
20	M45168-2	Winch Handle (...-2006)
21	M46770	Foam Rubber Stripping (...-2006)
22	.....	Coupling Weldment (...-2002)
	M48969	Coupling (2003)
23	M45165	Safety Hook
24	M45827	Cable Clamp
25	M48090	Pulley Modified
26	M45930	Cable. 1/8" x 140'
27	ROP8-12	Roll Pin, 1/8" x 3/4" (...-2006)
28	M46653	3/8" Hose, Flow Valve to Pump
29	M48974	Winch Weldment (2003 . . . )
	M49014	Winch Assy - Inboard (2007-...)
30	M46951	Coupling Spider
31	M46617	Flow Control Valve
32	M46930	Winch Cover Assembly
33	M48091-8	Reducer Adapter, 1/2M-1/4F
34	M46771-17	Nipple Adapter, 1/2P-3/8T
35	M48063	Winch Weldment (...-2006)
	M49015	Winch Assy - Outboard (2007-...)
36	M48015	Coupling Spider (...-2002)
	M48971	Coupling Spider (2003-...)
37	KW-91	Woodruff Key, 1/4"
38	M46764	Hand Crank Extension (...-2006)
39	M48017	Coupling (...-2002)
	M48970	Coupling (2003-...)
40	M48972	Spacer
41	M48973	Shim
42	M46624	Return Spring (...-2006)
43	M46625	Compression Spring

Figure 2-4  
END SECTION ASSEMBLY



Key No.	Part No.	Description
1	M45099-01	End Section Weldment
2	M48939	Winch (Manual Screed only)
3	M48090	Cable Pulley
4	M45827	Cable Clamp
5	M45165	Safety Hook
6	M45930	Cable, 1/8" x 140'
7	M45104	End Support Plate
8	M46765	Modified Eye Bolt, 3/8"-16
9	M45168-2	Winch Handle

## Bolt and Cap Screw Torque Specifications

MATERIAL SPEC AND MARKING	Hex Head Bolts & Hex Head Cap Screws			Socket Head Cap Screws	
	SAE Grade 2 ASTM A307 (No Mark)		Grade 5* ASTM A449		Grade 8* ASTM A354
				Grade 8	 ** 

\* Manufacturer's marks may vary

\*\* For Flat and Button Head Socket Cap Screws, use Grade 5 minimum recommended torque values.

Size (inches)	Grade 2 Recommended Torque ***				Grade 5 Recommended Torque ***				Grade 8 Recommended Torque ***			
	lb-ft		N•m		lb-ft		N•m		lb-ft		N•m	
	Min	Max	Min	Max	Min	Max	Min	Max	Min	Max	Min	Max
36528	5	6	6.8	8.1	9	11	12.3	14.9	12	15	16.3	20.3
36661	10	12	13.6	16.3	17	21	23.1	28.5	24	29	32.5	39.3
36592	20	23	27	31	35	42	48	57	45	54	61	73
36722	30	35	41	47	54	64	73	87	70	85	95	115
36526	45	52	61	70	80	96	108	130	110	125	149	170
36784	65	75	88	102	110	125	149	170	160	175	217	237
36653	95	105	129	142	150	175	203	237	220	245	298	332
36588	150	185	203	251	270	300	366	407	380	425	515	576
36714	160	200	217	271	400	450	542	610	600	660	814	895
1	250	300	339	406	580	680	786	922	900	990	1220	1342
1-1/8					800	880	1085	1193	1280	1440	1736	1953
1-1/4					1120	1240	1519	1681	1820	2000	2468	2712
1-3/8					1460	1635	1980	2217	2380	2720	3227	3688
1-1/2					1940	2180	2631	2956	3160	3560	4285	4827

\*\*\* Use minimum recommended torque value when threads are coated with lubricant, such as engine oil, or fasteners with phosphate and oil coatings. Use maximum recommended torque value for dry fasteners or zinc plated fasteners without any lubricant.

- NOTES:
1. This specification is intended to be a general guideline for coarse threaded hardware in ferrous materials (steel, Cast-iron).
  2. Thread engagements in non-ferrous materials (aluminum, brass, plastic, etc.) may not be adequate to allow torque specified above.
  3. Where a particular application gives specific torque values, use them in lieu of those given above.

# WARRANTY

(Limited See Below)

## MASTER - LIGHT EQUIPMENT

Subject to all of the terms stated hereon, Master Equipment (the "Company") warrants to the original wholesale or O.E.M. purchaser and/or to the original retail purchaser only, that those components of each new trowel, compactor, vibrator, screed and chainsaw (the "Product") and any replacement components or parts which are manufactured by it, under normal use and service will be free during the warranty period from defects in material and workmanship. This warranty expires upon the occurrence of the earliest of any of the following: (1) the Product has been in operation more than 12 months after the date of delivery to its original user-purchaser (such date to be determined from the delivery record if any filed with the Company at East Moline, Illinois; otherwise such date shall be the date of delivery to the original dealer or distributor); (2) the Product is used for any purpose other than those purposes for which it was designed; (3) the Product is repaired other than by a Distributor of the Company or is altered outside the Company's factory in any way so as in the Company's judgement to affect adversely its safety or reliability; (4) the Product has been subject to misuse, negligence or accident; (5) the Product is used for other than commercial or industrial use.

Any Product components or other Products furnished by the Company but manufactured by others are warranted only to the extent of the original manufacturer's warranty to the Company. With regard to any ARROW-MASTER Products other than original Product components or replacement parts, these Conditions of Sale and Limited Warranty shall apply unless otherwise specified in writing.

This warranty shall not apply to normal maintenance services (such as pre-delivery servicing, tightening of fasteners, adjustments) or to normal replacement of service items. Downtime and loss of rental or revenue are specifically excluded.

Should the goods, equipment or merchandise described hereon prove defective within the above warranty period, the Company will, at its option, repair or replace the same if returned by the Purchaser, freight prepaid, to an authorized Distributor of the Company for that product, provided that the Company is given written notice of any such claimed defect promptly and within the warranty period herein provided. The Company reserves the right to require the shipment of the allegedly defective product to the Company's plant, freight prepaid, for its examination prior to making warranty decision. Such product, if determined by the Company to be defective in materials or workmanship, will be repaired or replaced at the place of business of the Distributor where such product shall have been returned. Repair and/or replacement at the option of the Company shall be the sole and exclusive remedy of buyer for breach of the above express warranty, or otherwise.

**EXCEPT AS EXPRESSLY SET FORTH HEREIN, THE COMPANY MAKES NO WARRANTY EITHER EXPRESS OR IMPLIED, THAT THE GOODS, EQUIPMENT OR MERCHANDISE SHALL BE MERCHANTABLE OR FIT FOR ANY PARTICULAR PURPOSE OR USE, NOR DOES IT MAKE ANY OTHER WARRANTY, EXPRESS, IMPLIED OR STATUTORY. NO WARRANTY AGAINST INFRINGEMENT IS MADE.** The Company shall have no liability for incidental, consequential, special, general or other damages arising from the use of its product including but not limited to failure of the goods, equipment or merchandise to perform any general or particular function or purpose whether such damage or failure is due to a mistake or deficiency in any design, formula, plan, specifications, advertising material, printed instructions, defective materials, defective or improper workmanship, defective or improper assembly or otherwise, the sole liability of the Company being to repair or replace, at its option, defects in material or workmanship as stated in the preceding paragraph. The Company specifically does not warrant that the product shall meet or comply with the requirements of any particular state, or municipal safety codes or regulations; this includes jurisdictions outside the United States.



### MASTER EQUIPMENT

850 State Hwy 55, Brooten MN 56316

THIS WARRANTY WAS EFFECTIVE JANUARY 1, 2015

**ANY PRODUCT SHIPPED BY COMPANY PRIOR TO THIS DATE  
WAS COVERED BY WARRANTY IN EFFECT AT DATE OF SHIPMENT FROM COMPANY.**

**PLEASE READ ADDITIONAL TERMS AND CONDITIONS ON REVERSE SIDE CONTAINING  
LIMITATION OF WARRANTY, LIABILITY AND REMEDIES APPLYING TO THIS PRODUCT.**

**MASTER EQUIPMENT**  
**MASTER - LIGHT EQUIPMENT**

**CONDITIONS OF SALE**

**NOTICE TO CUSTOMER:** PLEASE READ CAREFULLY, THESE TERMS AND CONDITIONS CONTAIN DISCLAIMER OF WARRANTIES AND STRICT LIMITATIONS OF LIABILITY AND REMEDIES.

**CAPTIONS USED HEREIN ARE FOR CONVENIENT REFERENCE AND SHALL NOT AFFECT MEANING**

**DAMAGE TO PRODUCT.** The Company shall not have any responsibility or liability for damage to Products in shipment, during assembly, installation, erection or arising from accidents, abuse or improper operation of the goods, equipment or merchandise.

**SUPERSEDEANCE.** These terms and conditions shall supersede and, in case of conflict, shall control over any other terms or provisions in any oral or written purchase order or other document pertaining to the goods, equipment or merchandise described hereon, including any negotiations between the parties or contained in any product catalog or descriptive literature pertaining to the goods, equipment or merchandise referred to herein.

**OTHER WARRANTORS.** No distributor, dealer, franchisee independent sales representative or other person, firm or corporation has authority to make or assume any other obligation, warranty or liability on behalf of the Company, or to waive, modify or change these terms and conditions.

**ENGINEERING, PRODUCT, SAFETY, INSPECTION AND MAINTENANCE INFORMATION.** The authorized Distributor of Company's products is required to deliver to each original retail purchaser the Operator's and Maintenance Manual with Safety Rules, the Parts Manual and this Warranty. All users are cautioned to examine this information thoroughly and in full at the time of purchase and before starting or attempting to operate any Hammer or other Product of the Company. Notify Company if above documents are not received in good condition.

**STOPPAGES.** In the event of stoppage or partial stoppage of our plants or shipments of the items ordered by our customer, due to causes beyond our control, such as (but not limited to) strikes, differences with workmen, fires, floods, accidents, scarcity of labor, materials, power, fuel, transportation difficulties, war (whether in this country or abroad) governmental regulations, orders or proclamations, laws, acts of public enemies, mobs or rioters, or acts of God, deliveries hereunder may be suspended or partially suspended, during the continuance of such interruption.

**APPLICABLE LAWS.** The provisions of this instrument shall be constructed in accordance with, and the rights and liabilities of both the manufacturer and purchaser thereunder, shall be controlled by the laws of the State of Illinois, U.S.A., in force as of the date of shipment by the manufacturer.

**MISCELLANEOUS TERMS.** Prices and discounts subject to change without notice. Orders accepted with the understanding that price and discounts prevailing at the time of shipment shall apply.

Material may not be returned to Company without prior written permission. A restocking and re-shipping charge may be made, at Company's option, on items returned to Company. Returned items must be freight prepaid, and all transportation charges previously paid by Company will be charged back.

**WARRANTY SERVICE**

**Warranty Service will be performed by Authorized ARROW-MASTER Dealers upon delivery of machine, or defective parts to such dealers. The Purchaser shall pay the cost of any premium for overtime labor requested by the Purchaser and any charge for making service calls and for transporting the machine and/or parts thereof to and from the place where warranty work is performed.**

**CALIFORNIA PROPOSITION 65 WARNING:**  
Operation of this equipment and/or engine exhaust from this contains chemicals known to the State of California to cause cancer, birth defects, or other reproductive harm.